

12 VOLT TROLLING MOTOR

Model BM4212

173
IO

⚠ WARNING

- The supply cord cannot be replaced. If the cord is damaged the appliance should be scrapped.
- This appliance can be used by children aged from 8 years and above and persons with reduced physical, sensory or mental capabilities or lack of experience and knowledge if they have been given supervision or instruction concerning use of the appliance in a safe way and understand the hazards involved.
- Children shall not play with the appliance.
- Cleaning and user maintenance shall not be made by children without supervision.
- Always operate the motor at a safe distance away from swimmers, objects and obstructions. Never approach the motor when the propeller is running. Contact with a spinning propeller may cause serious injury or death.
- Always exercise safe practices when using your motor; stay clear of other watercraft, and all floating objects. Always obey water regulations applicable to your area of operation.
- Stop the motor immediately whenever anyone in the water is near the boat.
- Never operate the motor while under the influence of alcohol, drugs, medication, or other substances which may impair your ability to safely operate equipment.
- This motor is not suitable for use in strong currents and winds exceeding the thrust level of the motor.
- Never run your motor in any mode with the propeller outside of the water: contact with rotating propeller may result in serious injuries or death.
- When operating the motor in "weed escape" mode do not reach with your hand into the water or try to assist the weed removal. Always assure the motor is switched off and disconnected from the battery(s) before attempting any manual weed removal.
- Always set the speed selector to zero and place the motor in the deployed position before connecting power cables to the battery. Disconnect the power cables first prior to stowing. Disconnect the negative cable first and connect it last.
- Always ensure the power cables are not twisted or kinked and are securely routed to avoid tripping or a safety hazard. Ensure cables are unobstructed to avoid damaging the wire insulation. Damage to the insulation could result in failure, electric shock, or other injury.
- Always inspect the insulation of the power cables prior to use to ensure they are not damaged.
- Always disconnect the motor from the battery(s) before cleaning, servicing or checking the propeller.
- Never submerge the complete unit as water may enter the motor chamber through control box and shaft. Water in the motor may cause an electrical short circuit and void the warranty.
- Keep fingers clear of all hinges, pivot points and all moving parts when stowing, deploying, adjusting, raising or lowering the motor.
- Firmly grasp the motor shaft when adjusting the motor depth to prevent motor from falling.
- Regularly inspect and maintain the trolling motor according to these instructions. If you are not familiar with the correct procedures and safety precautions for servicing the motor, do not perform this service.
- Read and follow all instructions from the manufacturer of your battery and battery charger.

FAILURE TO FOLLOW THESE WARNINGS MAY RESULT IN PROPERTY DAMAGE, FIRE, ELECTRIC SHOCK, DROWNING, OR OTHER SERIOUS INJURY OR DEATH.

These product warnings, instructions and safety rules provided with the product represent some common risks of water recreation devices and do not cover all instances of risk and danger. Please use common sense and good judgement when enjoying any water activity.

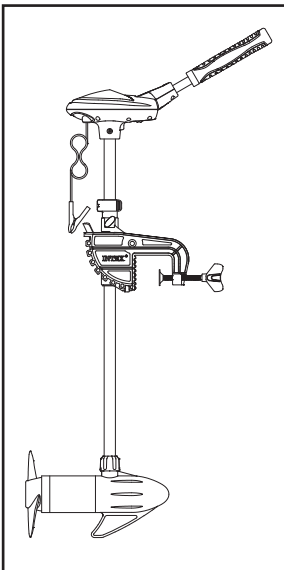

Voltage:	12V DC
Max. current:	35A
Max. power:	420W
Thrust:	40 Lbs (180N) Maximum loaded boat weight: 2000Lbs (909kg)
Speeds:	5-forward / 3-reverse
Shaft length:	36" (91.4cm)
Suitable for:	Freshwater and saltwater
Mounting type:	Transom mounting only

Requirement: a deep cycle marine 12volt battery with at least 60 ampere hours rating.

Note: All drawings for illustration purpose only. May not reflect actual product. Not to scale. Boat and battery are not included.

SAVE THESE INSTRUCTIONS

Overview:

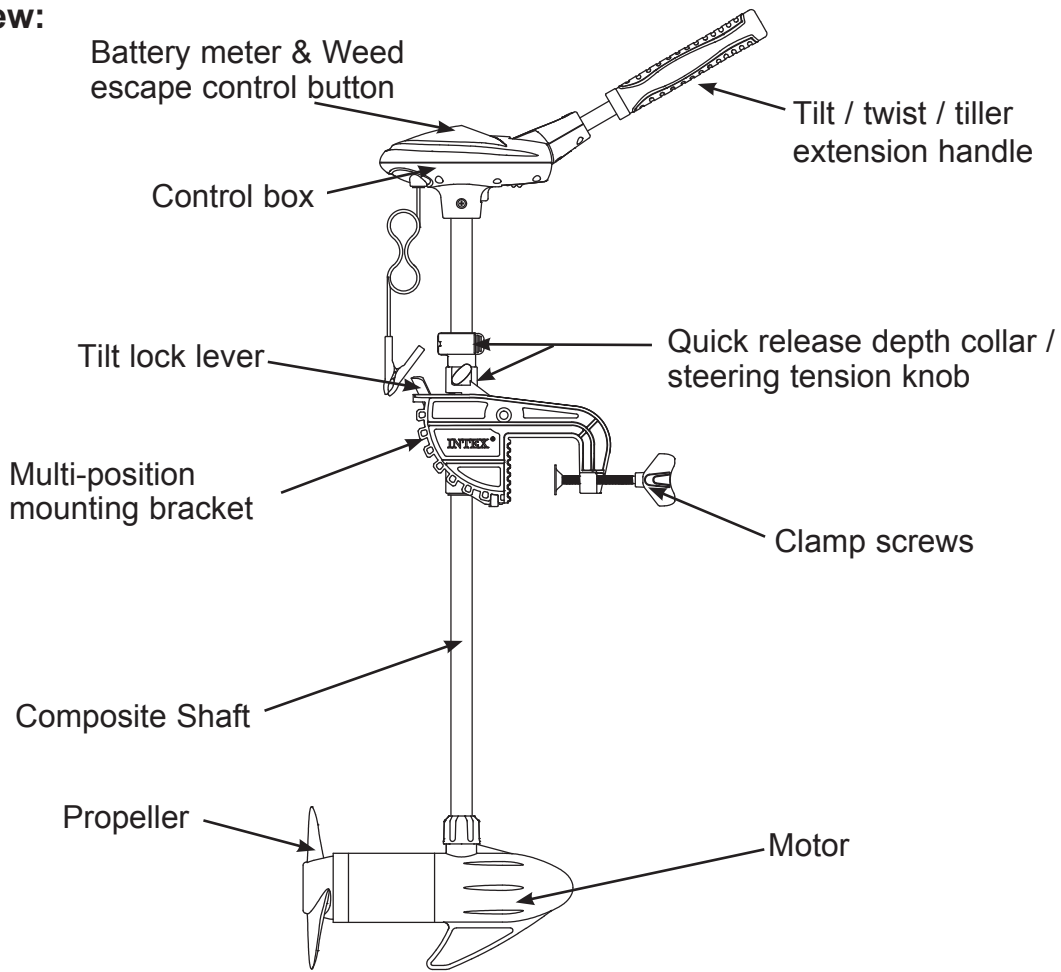

Due to a policy of continuous product improvement, Intex reserves the right to change specifications and appearance, which may result in updates to the instruction manual, without notice.

SETUP INSTRUCTIONS

Mounting

Install the motor mounting bracket on the transom / stern of the boat and tighten the clamp screws securely. **CAUTION:** Over-tightening the clamp screws can damage the motor mounting bracket.

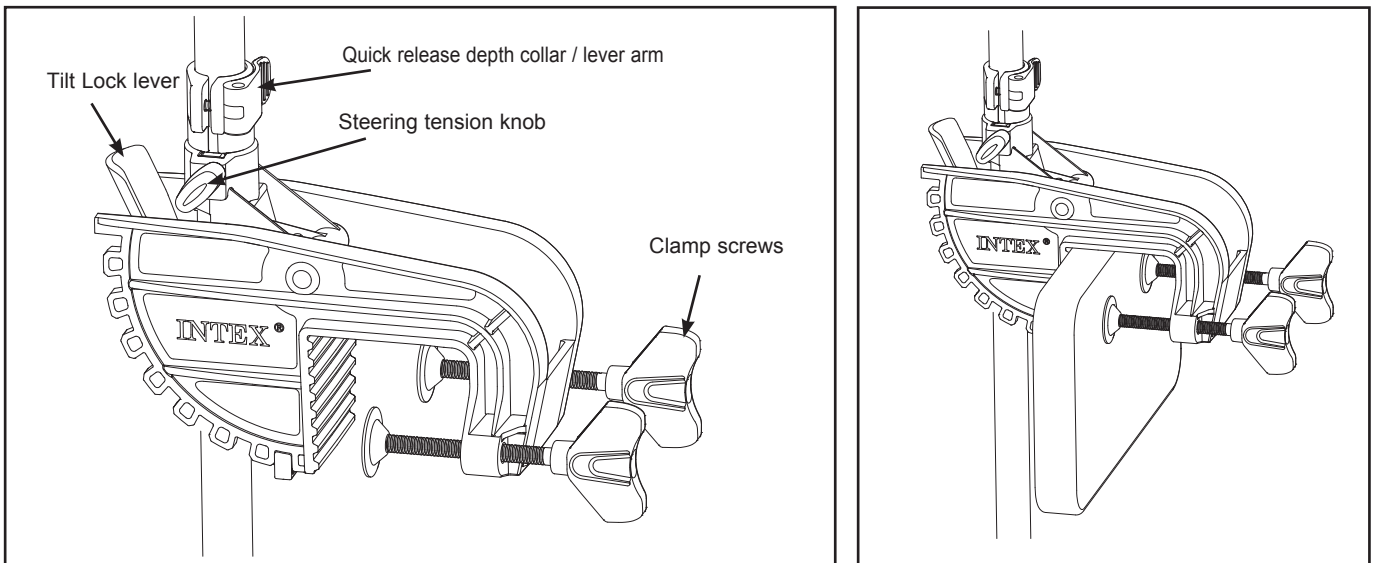

SAVE THESE INSTRUCTIONS

Shaft depth and steering tension adjustment

1. Open the lever arm of the quick release depth collar and slowly slide the shaft up or down to the desired depth. Close the lever arm back to secure the shaft depth. The lever arm of the quick release depth collar can be adjusted with a screwdriver to obtain the proper feel. **Note:** Do not over tighten the screw. **WARNING:** Keep fingers clear of all hinges, pivot points and all moving parts when stowing, deploying, adjusting, raising or lowering the motor. Always hold the shaft firmly when making adjustment to the quick release depth collar or the steering tension knob, as the motor can slide down quickly and cause injury.
2. The steering tension of the trolling motor can be adjusted by tightening or loosening the tension knob.

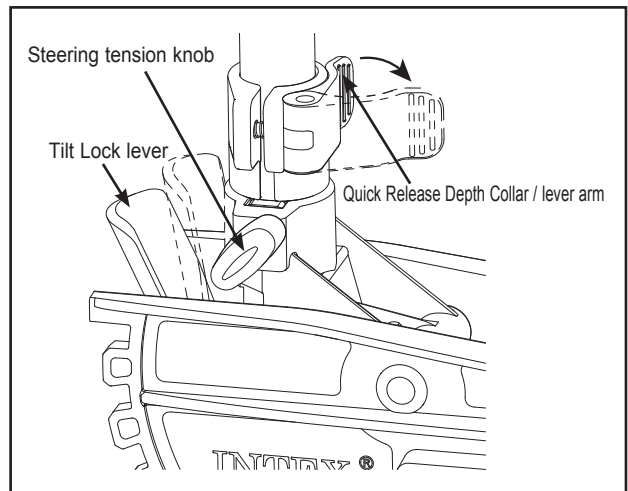
**Stowing, deploying and tilt angle adjustment****Horizontal stow:**

1. Loosen the steering tension knob, grab the back of the control box or the motor shaft. Do not use the handle to stow or tilt the motor.
2. While lifting up the motor 10" (25.4cm), tilt the trolling motor into the boat. The mounting bracket will ratchet into the locked position.
3. Re-tighten the steering tension knob and slide the quick release depth collar down to the top of the steering tension knob. Ensure the quick release depth collar is retightened.

Horizontal deploy:

1. To deploy the motor from the horizontal stowed position, loosen the quick release depth collar, reposition the depth collar and retighten to the desired depth position.
2. Hold the back of the control box or the motor shaft firmly, loosen the steering tension knob, press the tilt lock lever while holding the control box, and slowly lower the motor into the water.
3. Make sure the quick release depth collar is securely tightened to the desired depth and the steering tension knob is tightened to the desired steering tension.

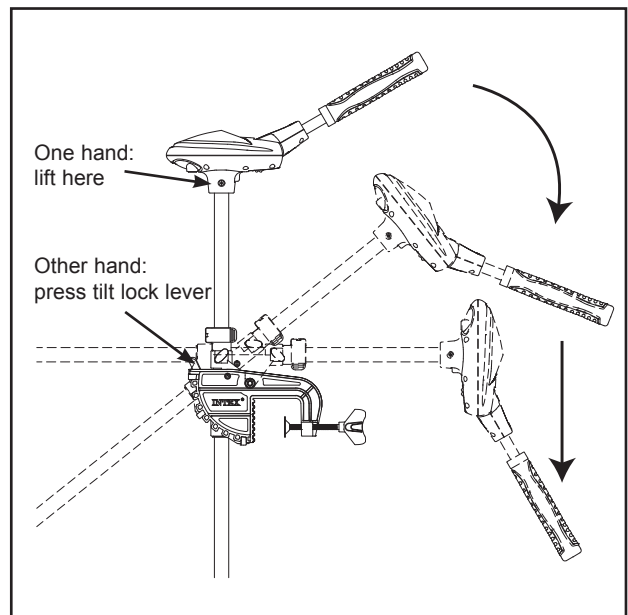
**Vertical stow:**

1. Hold the motor shaft firmly, loosen the steering tension knob and lift the motor up to the desired vertical position.
2. Retighten the steering tension knob to retain and secure the vertical stow position of the motor.
3. Open the quick release depth collar lever arm and slide the quick release depth collar down to the top of the steering tension knob. Close the lever arm.

Vertical deploy:

1. To deploy the motor from the vertical stowed position, loosen the quick release depth collar by opening the lever arm, hold the motor shaft firmly, loosen the steering tension knob and slowly lower the motor into the water to the desired depth.
2. Retighten the quick release depth collar, and retighten the steering tension knob to the desired steering tension.

SAVE THESE INSTRUCTIONS

Tilt and extension handle adjustment and operation

- There are 8 tilt positions: 15°, 30°, 45° upward, and 15°, 30°, 45°, 60°, 75° downward from 0° (horizontal position).
IMPORTANT: To use the downward position, you must press the release button located on the underside of the pivot handle, and then push the handle down until you feel the handle "lock in" to the desired position.
- To extend the handle, pull the handle towards you to the desired length position. The handle extends a 6 inches (15.2cm).
- To retract the handle, push the handle in until it meets the face of the control box head.

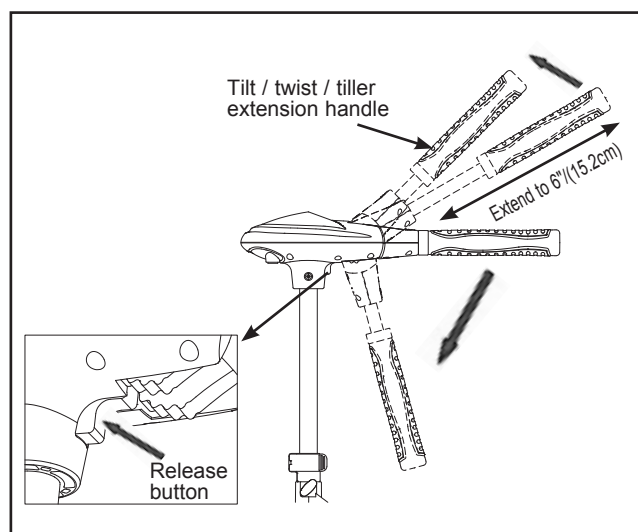

Switch ON/OFF and speed adjustment

There are 5 forward speeds (1, 2, 3, 4 and 5) and 3 reverse speeds (-1, -2 and -3)

- Twist the handle left or right to activate the motor.
- Twist the handle to 1, 2, 3, 4 and 5 to go forward and increase the forward speed accordingly.
- Twist the handle to -1, -2 and -3 to reverse and increase the reverse speed accordingly.
- Twist the handle to "0" to switch OFF.

IMPORTANT: If the propeller / motor is out of the water, the safety protection feature will prevent the motor from operating. Ensure the propeller/motor is submerged in the water.

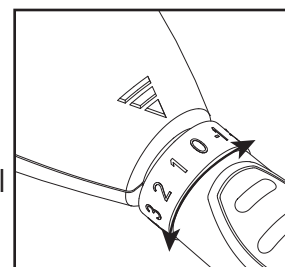

Battery requirement and connection

IMPORTANT: For best result use a deep cycle marine 12 volt battery (not included) with at least 60 ampere hours rating.

1. Make sure the motor is switched off (speed selector handle on "0").
2. Connect the positive (+) red wire to the positive (+) battery terminal.
3. Connect the negative (-) black wire to the negative (-) battery terminal.

The battery meter on the control box panel provides an indication of the remaining charge in the battery. Four lights indicate full charge; three lights indicate good charge; 2 lights indicate low charge and one light indicates that the battery must be recharged.

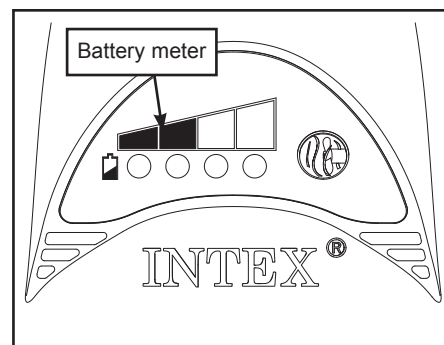

NOTICE: Maintain battery at full charge. Failure to recharge the battery within 12-24 hours is the leading cause of premature battery failure. Proper care will ensure having battery power when you need it and improve the battery life. Check with your local marine battery supplier for further details.

WARNING

- Never switch the motor on when the propeller is out of the water.
- Never connect the (+) and the (-) terminals of the battery together.
- Never allow metal objects to come into contact with the battery terminals.
- Always cover the battery and the battery terminal clamps.

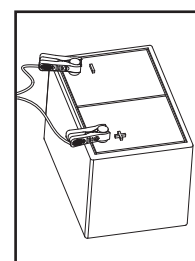

Weed escape control button

If weeds are entangled with the propeller, press and hold the "weed escape" button on the control box panel. The propeller will rotate back and forth to disentangle itself from the weeds.

NOTICE: Ensure the control handle is in "0" position first, then press the weed escape button.

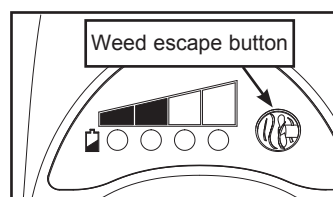

SAVE THESE INSTRUCTIONS

Boat rigging and motor installation

An over-current protection device (circuit breaker or fuse) must be used with this motor. The Coast Guard requires that each ungrounded current-carrying conductor must be protected by a manually reset, trip-free circuit breaker or fuse. The type (voltage and current rating) of the fuse or circuit breaker must be sized accordingly to the trolling motor used. The following breaker sizes are recommended guidelines:

Maximum thrust voltage recommended circuit breaker rating

30# to 45# 12V 50A @ 12VDC

50# to 55# 12V 60A @ 12VDC

The appropriate wire size needed to connect your trolling motor to the trolling motor batteries varies depending on the length of the cable needed and voltage of the motor. For further information and requirements, consult with your local ABYC (American Boat and Yacht Council, for USA) and Coast Guard.

Propeller replacement

1. Disconnect the motor cables from the battery before changing the propeller and servicing.
2. Hold the propeller and loosen the propeller nut with pliers or a wrench.
3. Remove the propeller nut and washer. If the drive pin is sheared or broken, hold the propeller shaft steady with a flat screwdriver pressed into the slot on the end of the propeller shaft.
4. Turn the old propeller to horizontal position and pull it straight off. If the drive pin falls out, push it back in.
5. Before installing the new propeller, make sure the drive pin is aligned 90 degrees with the small guiding studs.
6. Align the new propeller with the drive pin and press into place.
7. Re-install propeller washer and nut.
8. Tighten the nut 1/4 turn past snug. Do not over-tighten the nut.

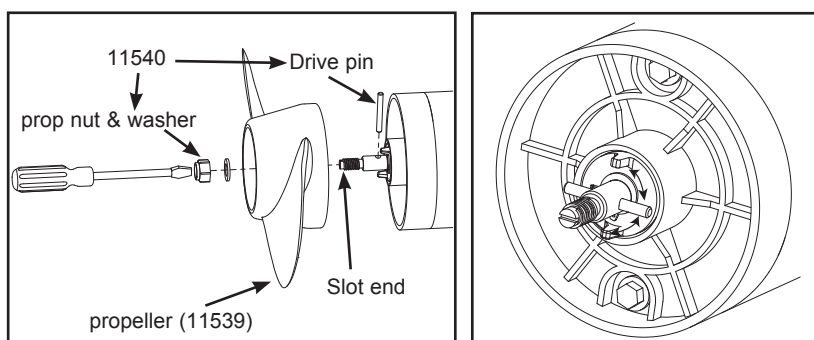

Maintenance

- After each use, rinse with fresh water and then dry out with a cloth dampened with a water based silicone spray.
- After each use, the propeller must be cleaned of weeds, fishing line or any objects. Fishing line and other objects can get behind the propeller, wear away the seals and allow water to enter the motor. Regularly check the propeller/motor seal for wear and tear.
- Before each use, ensure the propeller nut is securely tightened.
- To prevent accidental damage during traveling, stowing and/or storage, disconnect the motor cables from the battery whenever the motor is out of the water. For long term storage, lightly coat all metal parts with a water based silicone spray. Do not store in freezing temperatures below 32°F / 0°C.
- For maximum performance, restore battery to full charge before each use.
- Keep battery terminals clean with fine sandpaper or emery cloth.
- The propeller is designed to provide weed free operation with very high efficiency. To maintain this performance, the leading edge of the blades must be kept smooth. If they are rough or nicked from use, restore by sanding with fine sandpaper.

Troubleshooting:

1. Motor fails to run or lacks power:
 - a. Check motor for obstructions. The motor may have gone into current limit. To reset: return handle to off position, remove obstruction and resume operation.
 - b. Check battery connections for correct polarity.
 - c. Ensure terminals are clean and corrosion free. Use fine sand paper or emery cloth to clean the terminals.
 - d. Check battery water level. Add water if needed.

SAVE THESE INSTRUCTIONS

2. Motor loses power after a short running time:
 - a. Check the battery charge. If low, restore to full charge.
3. Motor is hard to steer:
 - a. Loosen the steering tension knob on the top of the mounting bracket.
 - b. Lubricate the composite shaft.
4. Bracket shifts or "walks" on the transom:
 - a. With some boats, the transom bracket may loosen or shift during heavy use. Retighten the clamp screws.
5. You experience propeller vibration during normal operation:
 - a. Ensure the propeller is free of objects and entanglements.
 - b. Remove and rotate the propeller 180 degrees. See removal instructions in propeller section.
 - c. Ensure battery terminals are clean.

PROBLEM	CAUSE	SOLUTION
Motor does not start, power indicator does not turn on	<ol style="list-style-type: none"> 1) Power is not turned ON / battery cable clamps are loose. 2) Battery cable clamps' polarity reversed. 3) Low battery power. 	<ol style="list-style-type: none"> 1) Twist the handle to ON / ensure battery cable clamps are secured and tighten. 2) Reverse and ensure correct polarity connection, then turn ON. 3) Recharge or replace the battery
Motor does not work, power indicator flashes	<ol style="list-style-type: none"> 1) Battery voltage is too high. 2) Control handle is not in "O" position. before switch ON or under protection mode. 	<ol style="list-style-type: none"> 1) Replace with a 12V marine battery, then switch ON. 2) Ensure control handle is in "O" position before twisting to the desired speed.
Motor suddenly stop	<ol style="list-style-type: none"> 1) Propeller, motor out of the water. 2) Weed, objects entangled with the propeller. 3) Low battery power. 	<ol style="list-style-type: none"> 1) Ensure propeller and motor are below the water surface. 2) Turn OFF, remove weed, objects from the propeller. 3) Recharge or replace battery.
Battery only last a short time	<ol style="list-style-type: none"> 1) Battery not fully charged. 2) Deteriorated battery. 	<ol style="list-style-type: none"> 1) Fully charge the battery. 2) Replace with a new battery (use a 12V / 60Ah marine battery).
Control handle is not responding	<ol style="list-style-type: none"> 1) Under protection mode. 2) Water inside the control handle. 3) Others 	<ol style="list-style-type: none"> 1) Turn control handle to "O" position, then turn to your desired speed to reset the protection mode. 2) Turn OFF ("O" position), extend the handle and dry out, then turn ON. 3) Contact Intex Service Center.
Battery cable clamps are hot	<ol style="list-style-type: none"> 1) Battery cable clamps are loose. 2) Battery terminals and cable clamps are rusty. 	<ol style="list-style-type: none"> 1) Ensure cable clamps are secured and tighten. 2) Clean the battery terminals and the cable clamps.
Motor is vibrating heavily	<ol style="list-style-type: none"> 1) Propeller is not positioned in the right depth. 2) Weed, objects entangled with the propeller. 3) Propeller is loose or broken. 4) Transom mounting bracket or clamp screws is loose. 	<ol style="list-style-type: none"> 1) Adjust the propeller's depth. 2) Turn OFF, remove weed, objects from the propeller. 3) Tighten the propeller or replace a new propeller. 4) Tighten transom mounting bracket clamps and the steering tension knob.
Weed escape control button not responding	<ol style="list-style-type: none"> 1) Button not firmly pressed in. 2) Control handle is not in "O" position or under protection mode. 3) Others 	<ol style="list-style-type: none"> 1) Press and hold the button until the operation is over. 2) Ensure the control handle is in "O" position first, then press the weed escape button. 3) Contact Intex Service Center.
Move slowly	<ol style="list-style-type: none"> 1) Low battery power. 2) Weed, objects entangled with the propeller. 3) Propeller is not positioned in the right depth. 4) Propeller is loose or broken. 	<ol style="list-style-type: none"> 1) Recharge or replace the battery. 2) Remove weed, objects from the propeller, then turn on. 3) Adjust the propeller's depth. 4) Replace a new propeller.
Trolling motor depth cannot be adjusted	<ol style="list-style-type: none"> 1) Lever arm of the quick release depth collar is not open. 2) Steering tension knob is not open. 3) Obstruction in the mounting bracket. 	<ol style="list-style-type: none"> 1) Open the lever arm on the quick release depth collar. 2) Loosen the steering tension knob. 3) Clear and remove any objects obstructing the movement of the shaft.
Motor cannot be stowed because adjustable handle does not work	<ol style="list-style-type: none"> 1) Motor is too deep. 2) Adjustable handle is not in the correct position. 	<ol style="list-style-type: none"> 1) Adjust the motor depth, then lift up the motor to stow. 2) Move the adjustable handle to proper position, then lift up the motor to stow.

SAVE THESE INSTRUCTIONS

Limited Warranty

Your 12 Volt Trolling Motor has been manufactured using the highest quality materials and workmanship. All Intex products have been inspected and found free of defects prior to leaving the factory. This limited warranty applies only to the 12 Volt Trolling Motor.

This limited warranty is in addition to, and not a substitute for, your legal rights and remedies. To the extent that this warranty is inconsistent with any of your legal rights, they take priority. For example, consumer laws across the European Union provide statutory warranty rights in addition to the coverage you receive from this limited warranty: for information on EU-wide consumer laws, please visit the European Consumer Center website at http://ec.europa.eu/consumers/ecc/contact_en/htm.

This limited warranty applies only to the original purchaser and are not transferable. This limited warranty is valid for a period of two (2) years from the date of the initial retail purchase. Keep your original sales receipt with this document, as proof of purchase will be required and must accompany warranty claims or the limited warranty will be invalid.

If you find a manufacturing defect in the Trolling Motor during the warranty period, please contact the appropriate Intex Service Center listed in the separate "Authorized Service Centers" sheet. If the item is returned as directed by the Intex Service Center, the Service Center will inspect the item and determine the validity of the claim. If the item is covered by the provisions of the warranty, the item will be repaired or replaced, with the same or comparable item (at Intex's choice) at no charge to you.

Other than this warranty, and other legal rights in your country, no further warranties are implied. To the extent possibly in your country, in no event shall Intex be liable to you or any third party for direct or consequential damages arising out of the use of your Trolling Motor, or Intex or its agents' and employees' actions (including the manufacture of the product). If your country does not allow the exclusion or limitation of incidental or consequential damages, this limitation or exclusion does not apply to you.

You should note that this limited warranty does not apply in the following circumstances:

- If the Trolling Motor is subject to negligence, abnormal use or application, accident, improper operation, improper voltage or current contrary to operating instructions, improper maintenance or storage;
- If the Trolling Motor is subject to damage by circumstances beyond Intex's control, including but not limited to, ordinary wear and tear and damage caused by exposure to fire, flood, freezing, rain, or other external environmental forces;
- To parts and components not sold by Intex; and/or
- To unauthorized alterations, repairs or disassembly to the Trolling Motor by anyone other than Intex Service Center personnel.

Injury or damage to any property or person is not covered by this warranty.

SAVE THESE INSTRUCTIONS